

AK-54 Applicable for Spot, Twin head spot, Seam welders

Resistance Welding Controls

- Secondary feed-back constant current control
- Self-adjustment for maximum current
- 15 Weld schedules
- External schedule select
- Spot, Twin head spot and seam welder compatibility
- 3 Impulse weld schedules
- 9 Steppers / Linear stepper
- Up and Down slope
- 2 Pressure valve output and 7 operations
- Current 1, 2, 3 monitor with high/low monitor
- 3 easy-to-operate counters to aid in systematic quality control and tip dressing schedules
- PC and RS485 network interface



FORWEL

Versatile, easy-to-operate, microcomputer control unit.

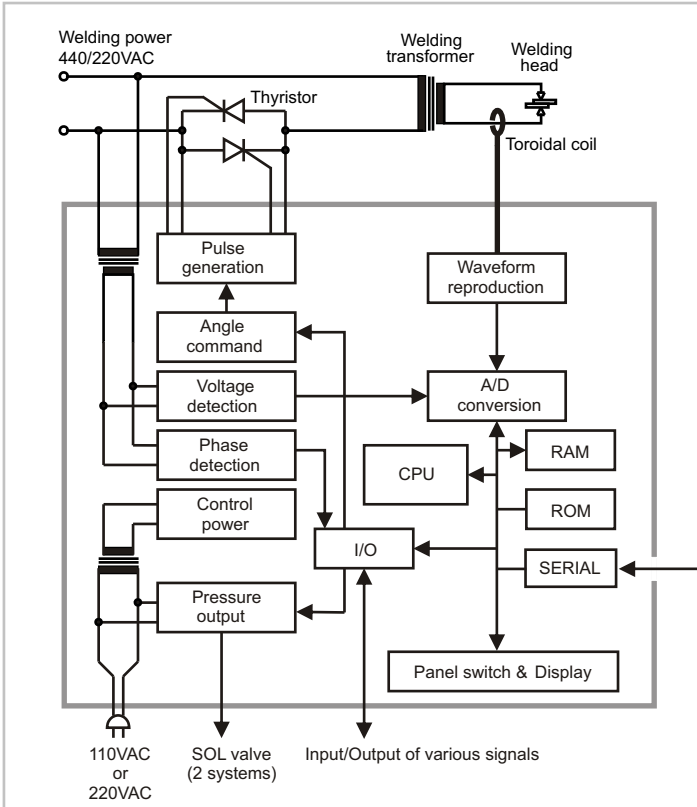

Constant current feed-back theory

Using a toroidal coil, the current wave form is reconstructed from the output signal. It is then transformed into an RMS effective value using the following formula:

$$RMS = \sqrt{\frac{1}{T} \int_0^T (i)^2 dt}$$

The control then compares this effective value with the set current value. The weld current is corrected with every half cycle through phase conversion and trigger pulse oscillation.

The result is smooth, consistent secondary welding current delivered at the weld regardless of the line voltage fluctuations.

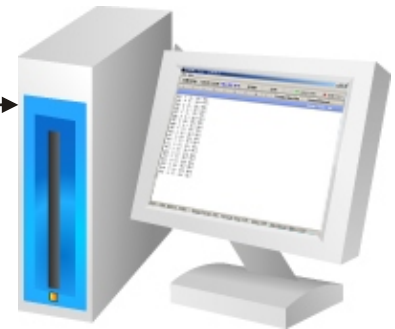

FRONT VIEW

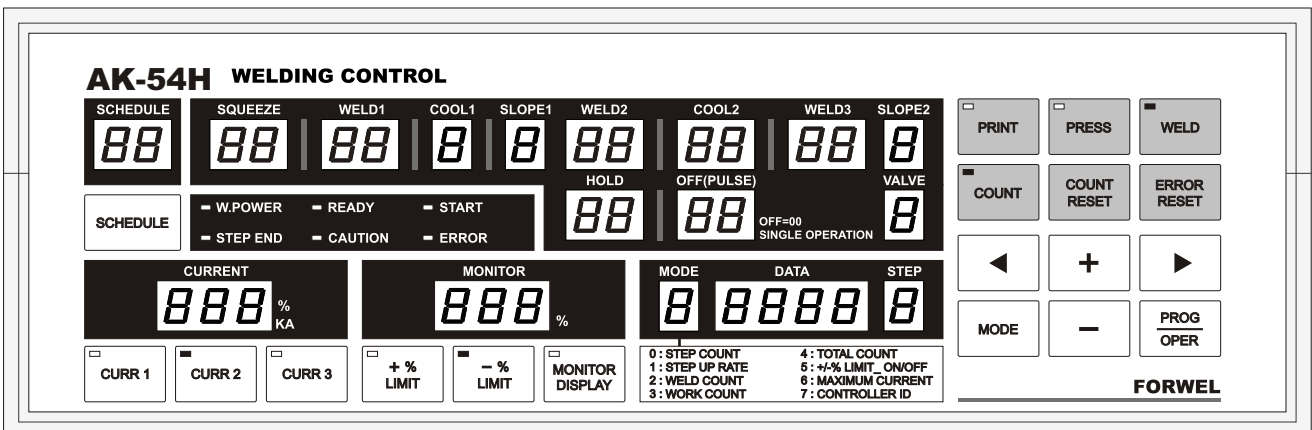

REAR VIEW

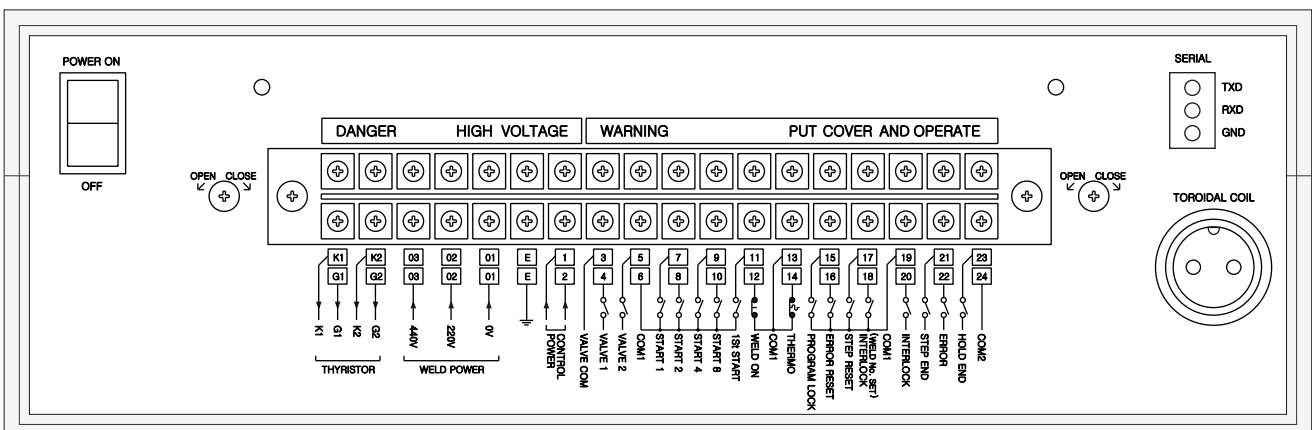

SPECIFICATIONS

		AK-54V	AK-54H
Power source	Welding power source	220VAC and 380/440VAC	
	Control power source	110VAC or 220VAC	
Frequency		50 /60Hz	
Control method		Secondary feed-back constant current control by phase control with thyristor or source voltage fluctuation compensation control method.	
Control speed	Secondary constant current control	1/2 cycle	
	Source voltage fluctuation compensation control	1 cycle	
Current accuracy	Welding power source voltage fluctuation	±2% for +10% /-15%	
	Resistance load fluctuation	±2% for ±15%	
	Inductive load fluctuation	±2% for ±15%	
Indication		7-Segment LED	
Program parameters	Schedule	15 schedules	
	Squeeze time	0..99 cycles	
	Weld1 time	0..9 cycles	
	Cool1 time	0..9 cycles	
	Up slope time	0..9 cycles	
	Weld2 time	0..99 cycles	
	Cool2 time	0..99 cycles	
	Weld3 time	0..9 cycles	
	Down slope time	0..9 cycles	
	Hold time	0..99 cycles	
	Off time / Pulsation	0..99 cycles / 0..9 times	
Valve	7 operations		
Maximum current setting range		3.0 to 80.0KA	
Current setting range		15 Schedules 1) Constant current control mode(0.3KA to 80.0KA) Current1,2,3 : 10% to 100% of maximum current setting 2) Source voltage fluctuation compensation control mode, Current1,2,3 : 00.0 to 99.9%	
Current monitor	Setting of upper limit	15 Schedules, ±0 to 49%	
	Setting of lower limit		
Valve output	System	Valve No.1 or 2 can be selected for 15 schedules and 7 operations	
	Output voltage	Relay contact output(1A), 24VDC(Optional)	
Stepper up of current	Step No.	0..9	
	Step count	0..9999	
	Step up rate	50..200%	
Counter	Weld count	0..99	
	Work count	0..9999	
	Total count	0..9999	
External input (Dry contact or open collector)	Program lock switch		
	Start 1,2,4,8 switch		
	Weld ON/OFF switch		
	Weld transformer or SCR temperature limit switch		
	Step reset switch		
	Error reset switch		
	Interlock / Weld No. Switch		
External contact output (250V 0.5A Max.)	Hold end output		
	Error output		
	Step end output		
	Interlock / Weld No. error output		
Serial output (Optional)		RS232 / RS485 interface	
Memory retention		10 years (EEPROM)	
Dimensions		85mm(W)x260mm(H)x207mm(D) 3.3"(W)x10.2"(H)x8.1"(D)	260mm(W)x850mm(H)x207mm(D) 10.2"(W)x3.3"(H)x8.1"(D)
Weight		2.6Kg (5.7lb)	
Toroidal coil		TC-450L, TC-600L(Optional)	

Time chart of basic operation

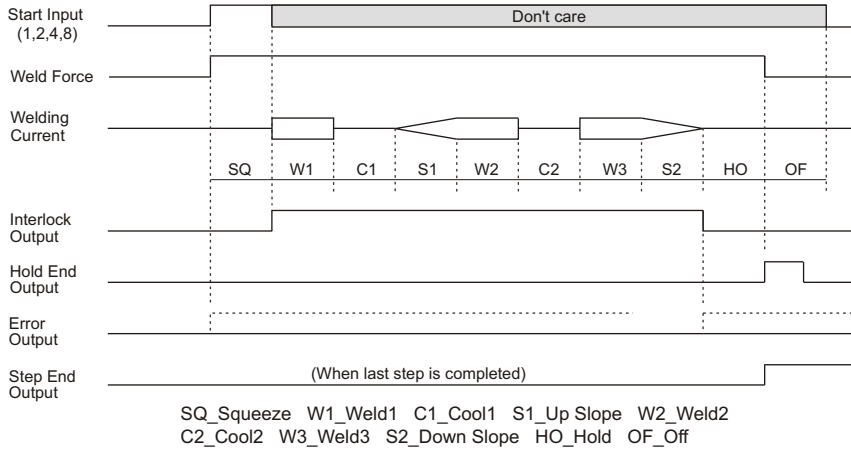

Time chart of pressure valve1 and 2

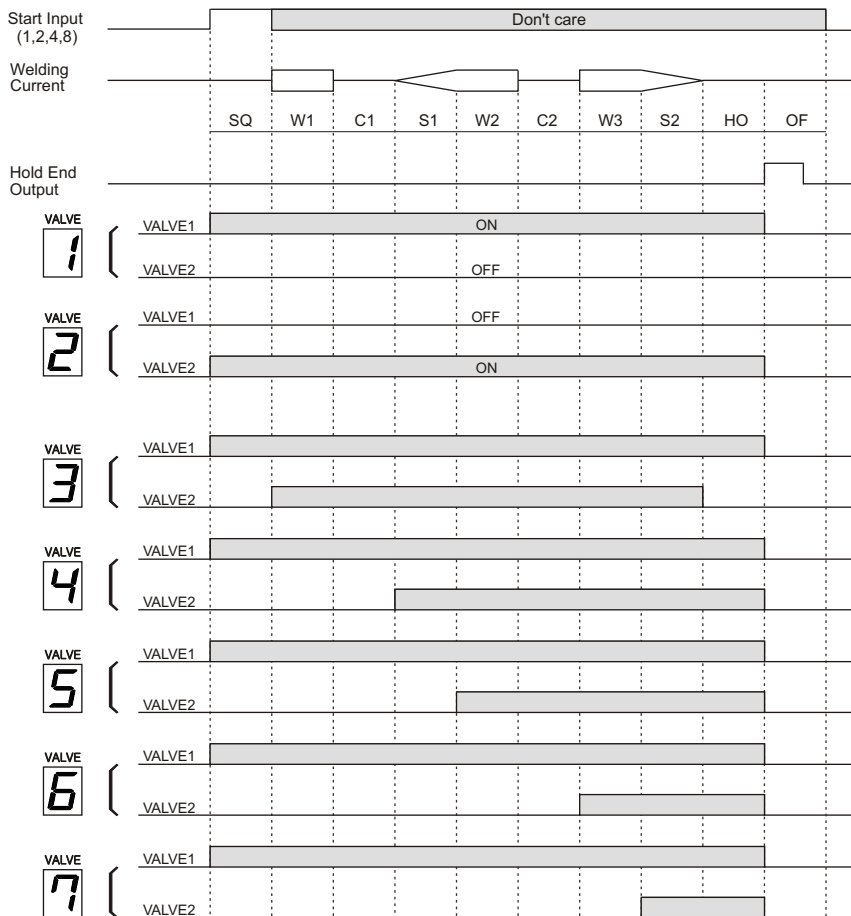

Time chart of seam welding operation

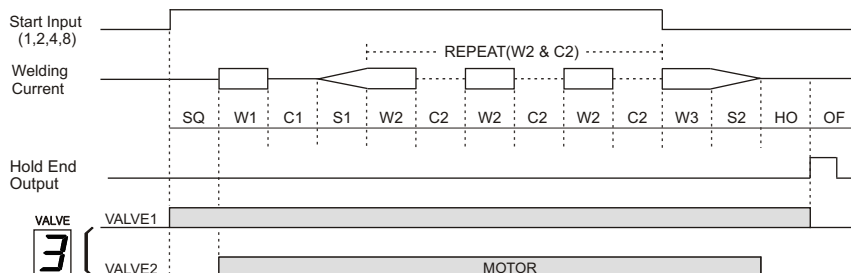

Printout of schedules

```

SCHEDULE_01 -----
SQ_60 W1_05 C1_03 S1_05
W2_10 C2_00 W3_05 S2_05
HO_30 OF_60 VALVE_1
CURR1 : 40.0 KA 05 CY
CURR2 : 50.0 KA 10 CY
CURR3 : 30.0 KA 05 CY
HIGH LIMIT : +01%
LOW LIMIT : - 01%

MODEL0,1_STEPPER -----
No. COUNT UPRATE CURRENT_KA
0 0500 100% CURR2_50.0
1 0490 122% CURR2_?61.0
2 0480 104% CURR2_52.0
3 0470 106% CURR2_53.0
4 0460 108% CURR2_54.0
5 0450 110% CURR2_55.0
6 0440 112% CURR2_51.0
7 0430 144% CURR2_?72.0
8 0420 116% CURR2_58.0
9 9999 118% CURR2_59.0
    
```

```

MODE2_PRESET WELD COUNT : 0 0 0 0
MODE3_PRESET WORK COUNT : 0 0 0 0
MODE4_PRESET TOTAL COUNT : 0 0 0 0
MODE5 +/-% LIMIT ON/OFF : 2 1 1 1
MODE6_MAXIMUM CURRENT(KA) : 60 . 0

DIP SWITCH1 : 00000000
DIP SWITCH2 : 00000000
    
```

If the calculated value of step up rate by the highest value among Curr1,2,3 exceeds the maximum current, "?" is printed.

Real-time printout of current1,2 and 3

COUNT	SCH	CURR1	CURR2	CURR3
0001	01	39.9	50.0	29.9
0002	01	40.1	50.0	30.0
0003	01	40.0	50.0	30.0
0004	01	40.0	50.0	30.0
0005	01	40.0	50.0	30.0
0006	01	39.9	50.0	30.0
0007	01	40.0	50.0	29.9
0008	01	40.0	50.0	30.0
0009	01	40.0	50.0	30.0
0010	01	39.9	50.0	30.0

Printout in case of current1,2 and 3 errors

COUNT	SCH	CURR1	CURR2	CURR3
0056	01	?40.8	50.0	30.0
1300	01	40.1	?51.2	30.0
1512	01	40.0	50.0	?30.7
1753	01	40.0	?48.9	30.0
2800	01	40.0	50.0	?29.3
3125	01	?39.1	50.0	30.0
4300	01	40.0	50.0	?31.0
4895	01	?39.0	?48.8	30.0
5230	01	40.0	50.0	?30.8
6812	01	?38.8	?48.7	?29.2

High Limit : +1%, Low Limit : -1%